



Commercial Specification Grade Straight Blade Receptacles

2 Pole, 3 Wire Grounding
Dual Voltage
15A 125V/15A 250V

INDUSTRIAL
COMMERCIAL
RESIDENTIAL

A-13 STRAIGHT BLADE RECEPTACLES

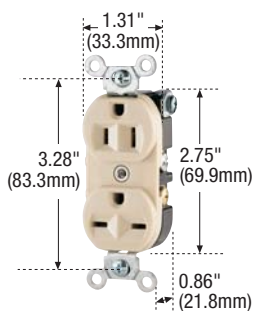

829

Duplex Receptacles

FEATURES

- Sturdy, compact design meets the demands of commercial spec grade performance.
- Excellent plug blade retention provided by triple-wipe 0.032" (0.81mm) triple-wipe brass line contacts and 0.050" (1.27mm) brass ground.
- High impact and chemical-resistant nylon face.
- 0.035" (0.889mm) galvanized steel, wrap-around yoke mounting strap for superior assembly security; extra length/width helps reach large panel cutouts for Code Compliance.
- Automatic grounding system eliminates need for bonding jumper in grounded metal enclosure, provides redundant measure of ground continuity where jumper used.
- Screw-Catch™ feature on duplex devices speeds mounting of wallplates.

Dual Voltage - Side Wire

Rating A	V/AC	NEMA	Color	Catalog No. Duplex
15	125/250	5-15R/6-15R	Brown	829B†
		5-15R/6-15R	Ivory	829V†

† Not NOM

TESTING & CODE COMPLIANCE

- Listed to UL 498 (file nos. E2369 & E15058).
- CSA Certified to C22.2 no. 42, (file no. LR7087 & file no. 6914 (6233-01)).
- NOM Certified.

MATERIAL CHARACTERISTICS

Meets flammability requirements per UL 94, V2 rated.
Temperature Rating:
-20°C to 60°C.



5-15R



6-15R

Commercial Specification Grade Straight Blade Receptacles

2 Pole, 3 Wire Grounding
15A 250V, 20A 125V,
15A 250V, 20A 250V,
20A 277V



INDUSTRIAL
COMMERCIAL
RESIDENTIAL

A-14 STRAIGHT BLADE RECEPTACLES

TESTING & CODE COMPLIANCE

- Listed to UL 498 (file nos. E2369 & E15058).
- CSA Certified to C22.2 no. 42, (file nos. LR7087 & 6914 (6233-01)).
- NOM Certified.

MATERIAL CHARACTERISTICS

Meets flammability requirements per UL 94, V2 rated.
Temperature Rating:
-20°C to 60°C.

Duplex And Single Receptacles

FEATURES

- Sturdy, compact design meets the demands of commercial spec grade performance.
- Excellent plug blade retention provided by triple-wipe 0.032" (0.81mm) triple-wipe brass line contacts and 0.050" (1.27mm) brass ground.
- High impact and chemical-resistant nylon face.
- 0.035" (0.889mm) galvanized steel, wrap-around yoke mounting strap for superior assembly security; extra length/width helps reach large panel cutouts for Code Compliance.
- Automatic grounding system eliminates need for bonding jumper in grounded metal enclosure, provides redundant measure of ground continuity where jumper used.
- Screw-Catch™ feature on duplex devices speeds mounting of wallplates.

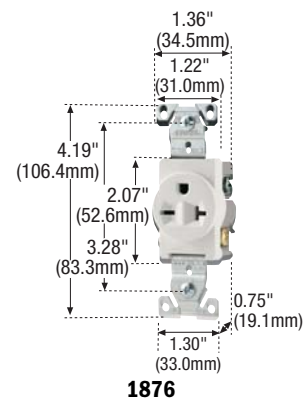
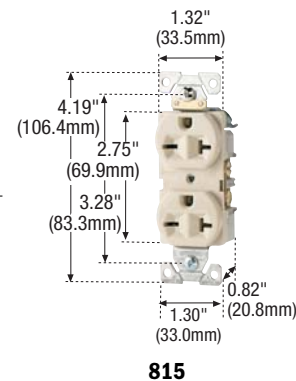
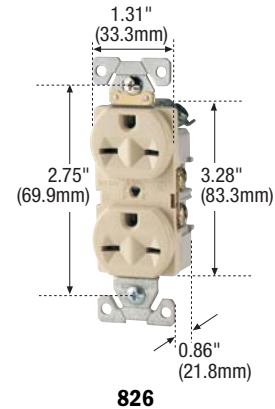

Side Wire			Catalog No.			
Rating			Colors	Duplex	Single*	
A	V/AC	NEMA				
15	125	5-15R	Almond	CR15A	817A	
			Black	CR15BK	—	
			Brown	CR15B	817B	
			Gray	CR15GY	—	
			Light Almond	CR15LA	817LA	
			Ivory	CR15V	817V	
			White	CR15W	817W	
20	125	5-20R	Almond	CR20A	1877A	
			Black	CR20BK	1877BK	
			Brown	CR20B	1877B	
			Gray	CR20GY	—	
			Light Almond	CR20LA	1877LA	
			Ivory	CR20V	1877V	
			White	CR20W	1877W	
15	250	6-15R	Almond	—	816A	
			Black	—	816BK	
			Brown	826B	816B	
			Light Almond	—	816LA	
			Ivory	826V	816V	
			White	826W	816W	
			20	250	6-20R	Almond
Black	—	1876BK				
Brown	815B	1876B				
Light Almond	—	1876LA				
Ivory	815V	1876V				
White	815W	1876W				

*Single receptacles meet all UL & CSA specifications, but differ in design and construction from duplexes noted above.

